

New



Hardware system for automatic sliding walls

HAWA-Motus 150/GV-matic



Move sliding glass walls with the greatest of ease
and park them in the smallest of spaces

HAWA-Motus 150/GV-matic

Are you looking for a hardware system that can move up to 20 sliding glass doors and park them in the smallest of spaces, all at the touch of a button? Then look no further – the HAWA-Motus 150/GV-matic is the automatic solution for your requirements. Its many advantages predestine the system for use in banks, open plan offices, shopping centres, airports, shopping arcades, and anywhere else where elegant and convenient sliding glass walls are needed for room partitioning.

About the product

This completely new Hawa design for automatic hardware moves sliding glass walls of up to 30 metres in width gently and quietly in high-quality top tracks. Its intelligent menu control sets new standards in user-friendliness with regard to both start-up and daily operation. And the groundbreaking hardware system is an unreserved pleasure for the eye, too, as every technical component is invisibly integrated into the top tracks. All the eye can see is an attractive glass retainer profile that emphasises the transparency of your glass system instead of detracting from it.



Just one finger to master operation: thanks to menu-driven controls.



Countless floor plans – 3 examples:

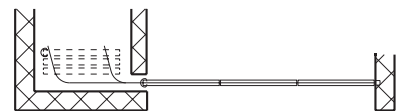

Parallel stacking in a recess.

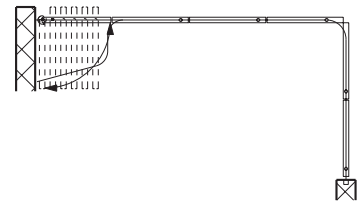

90° stacking for systems with directional change and pivot doors.

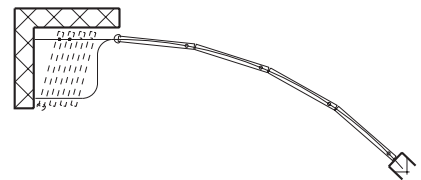

Fanned stacking for curved systems.

Technical specifications

Max. door weight	150 kg
Door width	850–1500 mm
Max. door height	3500 mm
Glass thickness	
ESG	10/12/12.7 mm
Max. no. of doors	20
Operating voltage	100–240 VAC
	50–60 Hz

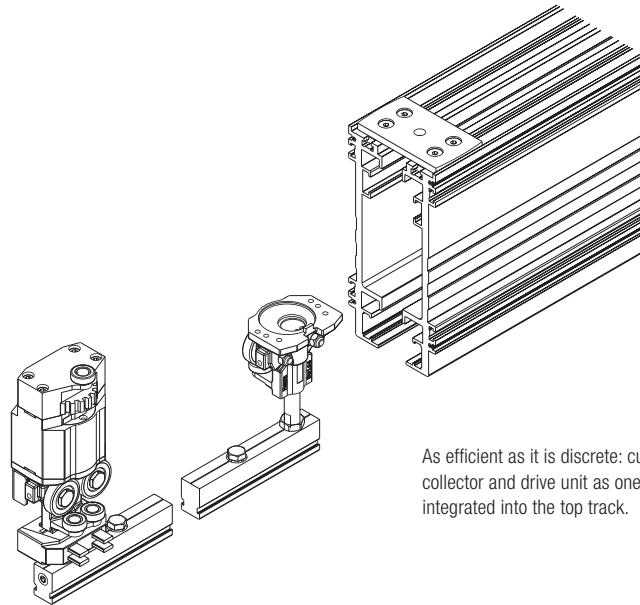

As efficient as it is discrete: current collector and drive unit as one unit integrated into the top track.

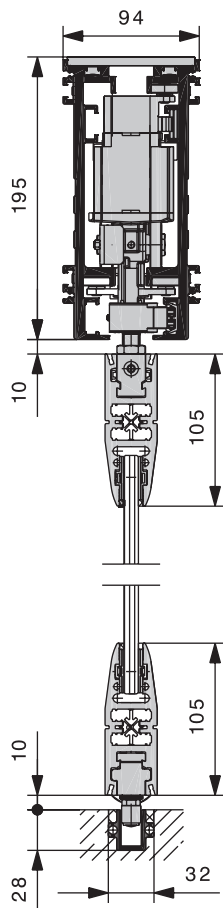

At a glance

- For up to 20 sliding glass doors with a maximum door weight of 150 kg.
- System widths of up to 30 metres.
- Various individual designs possible thanks to modular, pluggable top track system.
- Simple start-up thanks to menu-driven controls.
- No additional covers required as the drive technology is integrated into the top track.
- Intelligent drive, power supply and communications system for each door.
- Minimum space requirements in the parking area.
- Elegant design and secure automatic locking.
- Same appearance as HAWA-Variotec 150/GV profiles, therefore combinable with manual systems.
- Other door materials can be used in addition to glass.
- Very safe – system stops automatically when it encounters an obstacle.
- Retrospective automation easily possible.
- System is CE compliant.
- Extensive design and assembly documentation as well as guidelines and instructions for concept, installation and operation.

Available from authorised installers

Further information:

Hawa AG
CH- 8932 Mettmenstetten
Switzerland
Tel. +41 44 767 91 91
Fax +41 44 767 91 78
www.hawa.ch

